

# Black Bruin BBR HD rotator



**BBR HD rotator is the top choice for heavy duty harvesting and whenever productivity, strength and endurance are appreciated. Adjustable and wear-proof brake eases loading and damps swinging. BBR rotators are famous for reliability and suitability for different harvester head applications.**



**All-season sealing in the BBR series ensures that impurities won't get into your hydraulic system. BBR stands for reliability and suitability for different rotator applications.**

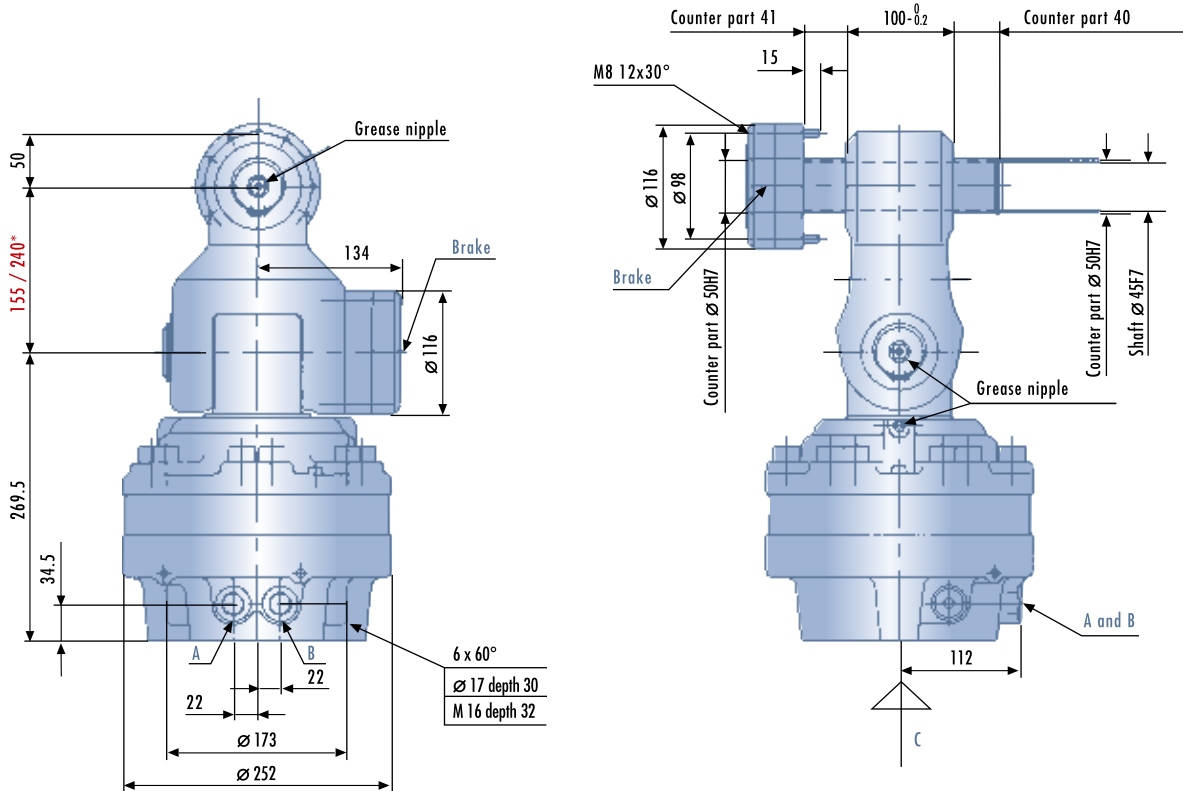

**A - Connection R1/2**  
**B - Connection R1/2**

### BBR HD rotator

- radial piston hydraulic motor
  - high loading capacity in radial and axial direction
  - built-in double-acting pressure relief valve
  - high pressure level
  - multi-disc brake damping
  - all-season sealing
  - heavy-duty tapered roller bearing
- \* two options for center link length (155mm and 240 mm)

Product code	Type	Weight (kg & lbs)	Rotation	Working pressure (max)	Torque (250 bar)	Axial load (max)	Relief valve opening pressure	Inlets
2770404108	BBR	57 kg, 126 lbs	Unlimited	250 bar	3000 Nm	150 kN	260 bar	R 1/2"
2770404008	+2 brakes+link	82 kg, 181 lbs		25 MPa	2212 lb-ft	33700 lbs	26 MPa	
2770404208	+2 brakes+long link	86 kg, 190 lbs		3600 psi			3800 psi	

## Black Bruin BBR HD rotator

### Durability and efficiency for harvesting heads

Black Bruin BBR HD rotator's unlimited rotation, excellent load capacity and constant torque throughout the turning range makes harvesting more efficient.

Built-in pressure relief valves in radial piston motor gives durability and reliability.

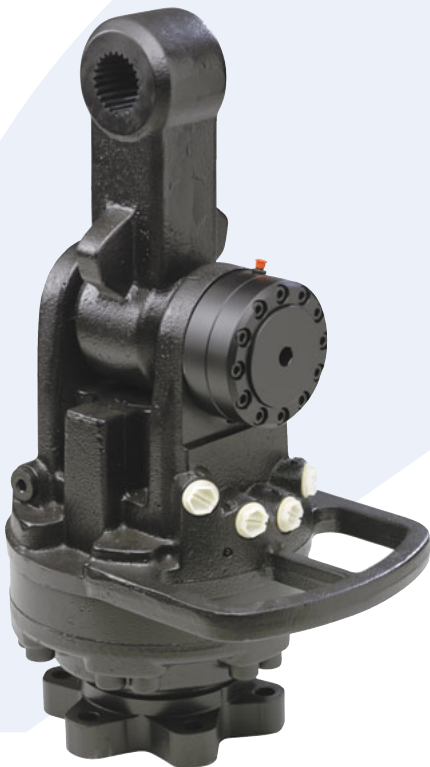

## Black Bruin BBR F rotator

### Heavy duty grapple rotator

Black Bruin BBR F rotator's unlimited rotation, excellent load capacity and constant torque throughout the turning range makes loading efficient.

Built-in pressure relief valves in radial piston motor gives durability and reliability.

## Black Bruin MR rotator

### Shows its claws as the loading crane rotator

Black Bruin MR hydraulic rotator is designed for rotating grapples of mobile cranes. The design takes into account the high external loads they are exposed to.

MR rotator is designed for professional use and rotator is very reliable and accurate. You can count on its productivity.

